



EDWARD M. BIRN
Director (Direktot)

EDITH C. PANGELINAN
Deputy Director (Sigundo Direktot)

**DEPARTMENT OF
ADMINISTRATION**
DIPATTAMENTON ATMENESTRASION

DIRECTOR'S OFFICE
(Ufisinan Direktot)

Telephone (Telifon): (671) 475-1101/1250 • Fax (Faks): (671) 477-6788



LOURDES A. LEON GUERRERO
Governor (Maga'håga)

JOSHUA F. TENORIO
Lt. Governor (Sigundo Maga'låhi)

April 29, 2020

DEPARTMENT OF ADMINISTRATION ORGANIZATIONAL CIRCULAR NO.: 2020-014

MEMORANDUM

To: All Line Department and Agency Heads and employees
From: Director, Department of Administration
Subject: **Novel Coronavirus (COVID-19)**
RE: Employee Face Coverings Guidance

Buenas yan Håfa Adai! It is important to remember that social distancing is still the primary way to slow the spread of the Novel Coronavirus (COVID-19), and should be maintained regardless of whether a person is wearing a mask or face covering. Pursuant to the Governor's Executive Order 2020-09, all essential businesses and government agencies shall require that their employees and patrons shall wear face masks while on their premises. Currently, commercial masks are in short supply and your respective department/agency may not be able to provide you with a commercial mask at this time. Please be assured, your department/agency is attempting to obtain a supply of mask and as they become available, we will attempt to provide you with one.

Essential employees are welcome to wear a face covering they bring from home. Face coverings from home may include items as cloth mask, surgical mask, shop/carpenter masks, bandanas, scarfs, neck gaiters, t-shirt, etc. Homemade face coverings can be made from a variety of materials such as cotton, silk or linen that covers the nose and the mouth and can be secured with ties, straps, or simply wrapped around the lower face. Regardless of the material, the face covering should be changed and/or washed daily and should not include any inappropriate message or print. Employees must practice strict hand washing before and after touching or adjusting their face covering. The U.S. Center for Disease Control and Prevention (CDC), provides guidance for making your own face covering, please see attached.

Should you have any questions, please contact the Department of Administration, Human Resources Division at 475-1288 or 475-1141. ***Dångkolo na Agradesimiento!***

EDWARD M. BIRN

Attachments

Use of Cloth Face Coverings to Help Slow the Spread of COVID-19

How to Wear Cloth Face Coverings

Cloth face coverings should—

- fit snugly but comfortably against the side of the face
- be secured with ties or ear loops
- include multiple layers of fabric
- allow for breathing without restriction
- be able to be laundered and machine dried without damage or change to shape

CDC on Homemade Cloth Face Coverings

CDC recommends wearing cloth face coverings in public settings where other social distancing measures are difficult to maintain (e.g., grocery stores and pharmacies), **especially** in areas of significant community-based transmission.

CDC also advises the use of simple cloth face coverings to slow the spread of the virus and help people who may have the virus and do not know it from transmitting it to others. Cloth face coverings fashioned from household items or made at home from common materials at low cost can be used as an additional, voluntary public health measure.

Cloth face coverings should not be placed on young children under age 2, anyone who has trouble breathing, or is unconscious, incapacitated or otherwise unable to remove the cloth face covering without assistance.

The cloth face coverings recommended are not surgical masks or N-95 respirators. Those are critical supplies that must continue to be reserved for healthcare workers and other medical first responders, as recommended by current CDC guidance.

Should cloth face coverings be washed or otherwise cleaned regularly? How regularly?

Yes. They should be routinely washed depending on the frequency of use.

How does one safely sterilize/clean a cloth face covering?

A washing machine should suffice in properly washing a cloth face covering.

How does one safely remove a used cloth face covering?

Individuals should be careful not to touch their eyes, nose, and mouth when removing their cloth face covering and wash hands immediately after removing.

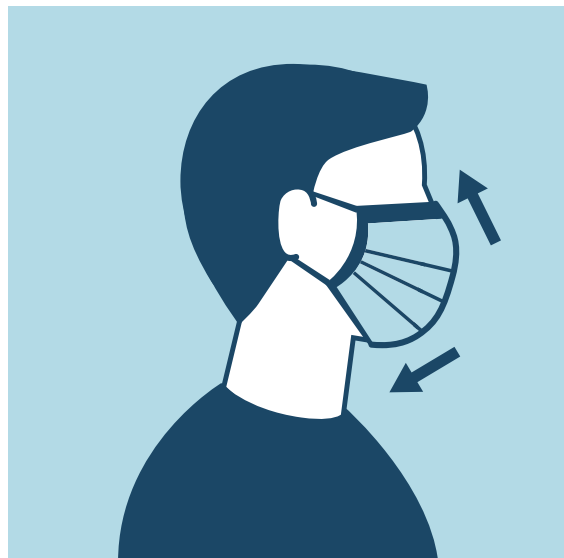

cdc.gov/coronavirus

Sewn Cloth Face Covering

Materials

- Two 10"x6" rectangles of cotton fabric
- Two 6" pieces of elastic (or rubber bands, string, cloth strips, or hair ties)
- Needle and thread (or bobby pin)
- Scissors
- Sewing machine

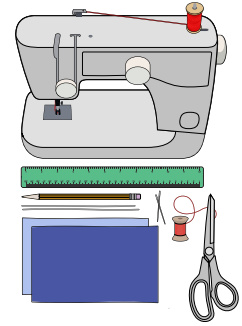

Tutorial

1. Cut out two 10-by-6-inch rectangles of cotton fabric. Use tightly woven cotton, such as quilting fabric or cotton sheets. T-shirt fabric will work in a pinch. Stack the two rectangles; you will sew the cloth face covering as if it was a single piece of fabric.

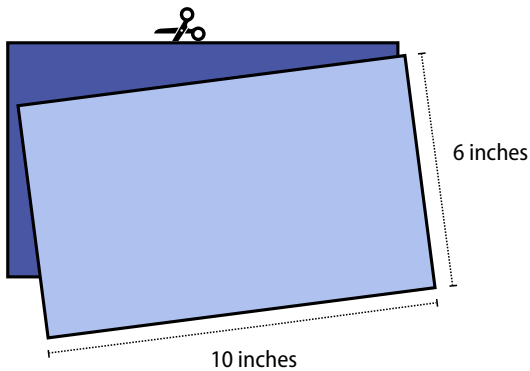

2. Fold over the long sides $\frac{1}{4}$ inch and hem. Then fold the double layer of fabric over $\frac{1}{2}$ inch along the short sides and stitch down.

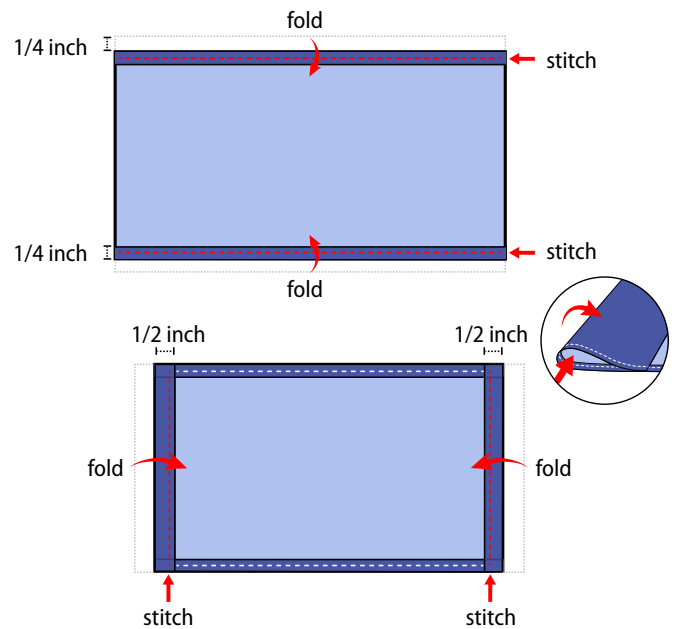

3. Run a 6-inch length of $\frac{1}{8}$ -inch wide elastic through the wider hem on each side of the cloth face covering. These will be the ear loops. Use a large needle or a bobby pin to thread it through. Tie the ends tight. Don't have elastic? Use hair ties or elastic head bands. If you only have string, you can make the ties longer and tie the cloth face covering behind your head.

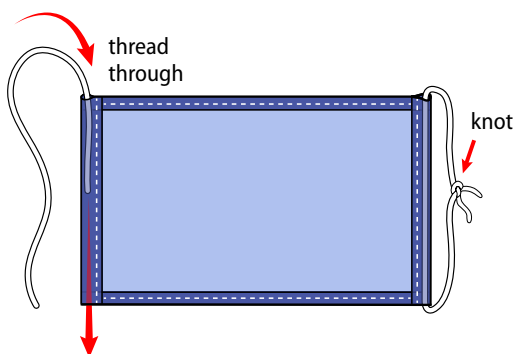

4. Gently pull on the elastic so that the knots are tucked inside the hem. Gather the sides of the cloth face covering on the elastic and adjust so the mask fits your face. Then securely stitch the elastic in place to keep it from slipping.

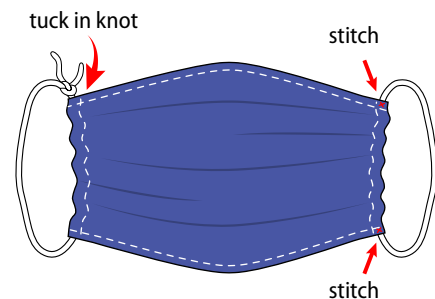

Quick Cut T-shirt Cloth Face Covering (no sew method)

Materials

- T-shirt
- Scissors

Tutorial

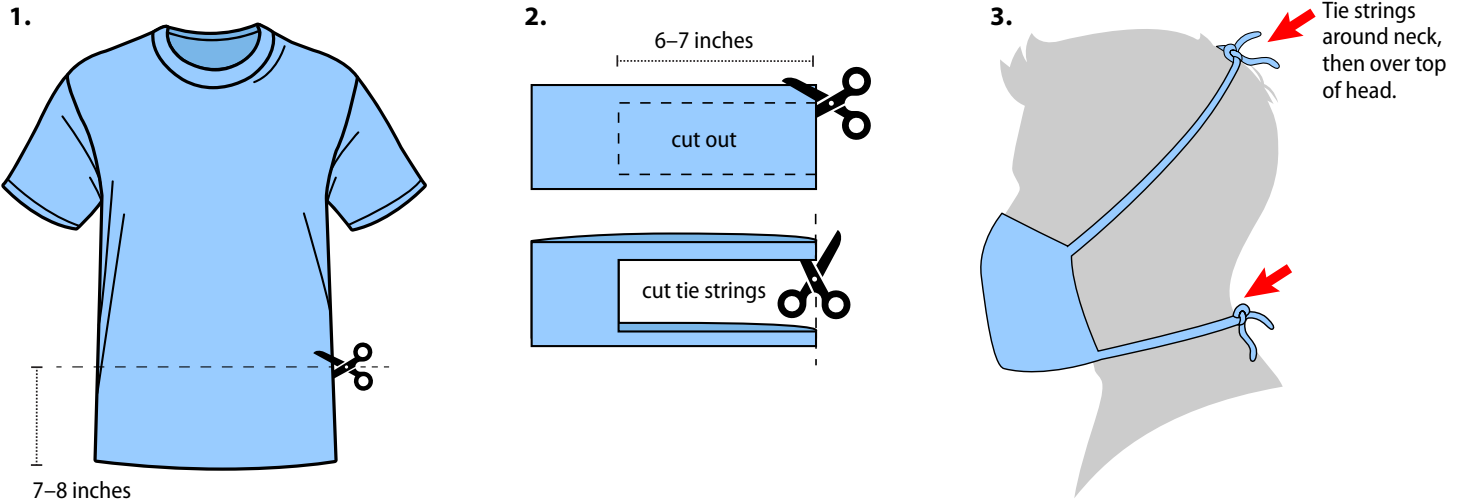

Bandana Cloth Face Covering (no sew method)

Materials

- Bandana (or square cotton cloth approximately 20"x20")
- Rubber bands (or hair ties)
- Scissors (if you are cutting your own cloth)

Tutorial

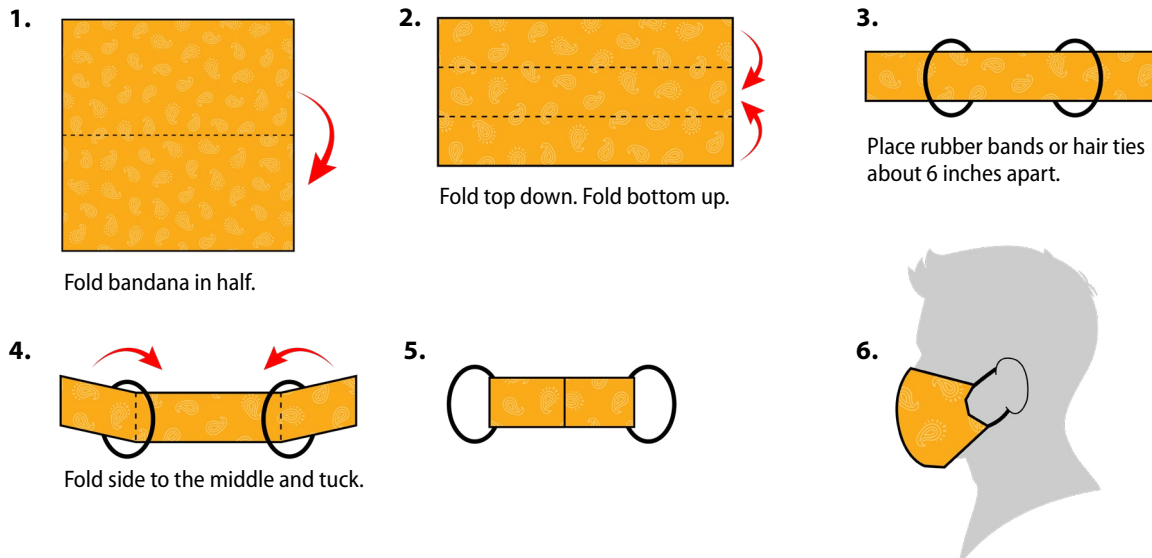

LOURDES A. LEON GUERRERO
MAGA'HÅGA • GOVERNOR



JOSHUA F. TENORIO
SIGUNDO MAGA'LÅHI • LIEUTENANT GOVERNOR

Via Hand Delivery
and E-mail: speaker@guamlegislature.org

April 5, 2020

HONORABLE TINA ROSE MUÑA BARNES

Speaker

I Mina'trentai Singko Na Liheslaturan Guåhan

35th Guam Legislature

Guam Congress Building

163 Chalan Santo Papa

Hagåtña, Guam 96910

Re: Executive Order No. 2020-09

Dear Madame Speaker:

Pursuant to Public Law 34-16, transmitted herewith is the following Executive Order:

EXECUTIVE ORDER NO. 2020-09:
RELATIVE TO ADDITIONAL SOCIAL ISOLATION
MEASURES

If you have any questions, please contact my office at # 475-9475/76.

Senseramente,

A handwritten signature in black ink, appearing to read "Sophia Santos Diaz".

SOPHIA SANTOS DIAZ

Legal Counsel

Enclosure(s): Executive Order No. 2020-09

cc via email: *Maga'hågan Guåhan*
Sigundo Maga'låhen Guåhan
F. Philip Carbullido, Chief Justice of Guam
Compiler of Law
Central Files
Cabinet Members



**ISLAND OF GUAM
OFFICE OF THE GOVERNOR
HAGÁTÑA, GUAM 96932
U.S.A.**

EXECUTIVE ORDER NO. 2020-09

**RELATIVE TO ADDITIONAL
SOCIAL ISOLATION MEASURES**

WHEREAS, On March 14, 2020, I, Lourdes A. Leon Guerrero, *I Maga'hågan Guåhan*, Governor of Guam, acting pursuant to the power provided to me by the Organic Act and the laws of Guam, declared a public health emergency in Executive Order No. 2020-03 in the island of Guam, due to the potential dangers posed by the 2019 novel coronavirus ("COVID-19"); and

WHEREAS, four (4) additional executive orders have been issued to mitigate the spread of COVID-19 by mandating social-distancing practices, suspending non-essential activities, imposing mandatory quarantine procedures on individuals arriving on Guam, prohibiting gatherings of more than fifty (50) individuals; and

WHEREAS, despite all the efforts that we have taken to slow the spread of COVID-19, our island has suffered the loss of four (4) members of our community; and

WHEREAS, statistical models demonstrate that the efforts our community has taken have helped slow the spread of infection; and

WHEREAS, even when accounting for the measures taken so far, these statistical models still project a further increase in the rate of transmission, the rate of hospitalization, and unfortunately, the number of potential deaths; and

WHEREAS, we are now in a position to further change the projections by escalating our efforts to slow the spread; and

WHEREAS, it is clear that the circumstances that necessitated my declaration of a public health emergency will continue beyond the current expiration date of April 13, 2020 and that an extension of the declared public health emergency is appropriate.

NOW, THEREFORE, I, LOURDES A. LEON GUERRERO, I Maga'hågan Guåhan, Governor of Guam, by virtue of the authority vested in me by the Organic Act of Guam, as amended, do hereby order:

1. **EXTENDING THE PUBLIC HEALTH EMERGENCY.** Effective today, the public health emergency first declared in Executive Order No. 2020-03 and which is set to expire on April 13, 2020 is extended for a thirty (30) day period. All provisions outlined in Executive Order Nos. 2020-03 through this Order shall continue in full force and effect until May 5, 2020.
2. **PROHIBITION ON SOCIAL GATHERINGS.** Pursuant to Section 3317, Article 3, Chapter 3, Title 10 of the Guam Code Annotated, effective immediately and until May 5, 2020, gatherings of any type, whether public or private, are prohibited. This provision shall not apply to gatherings of individuals from within a single household or immediate family unit.

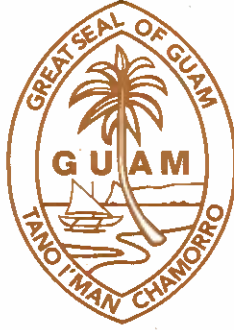

**ISLAND OF GUAM
OFFICE OF THE GOVERNOR
HAGÁTÑA, GUAM 96932
U.S.A.**

3. **PROHIBITION OF CONSUMPTION OF ALCOHOL ON PUBLIC PREMISES.** Effective immediately and until May 5, 2020, consumption of alcohol in any public premises shall be prohibited.
4. **EMERGENCY MEASURES CONCERNING FACILITIES AND MATERIALS.** All essential businesses and government agencies shall require that their employees and patrons shall wear face masks while on their premises. Relative to the prohibition on operations set out in Item 2 of Executive Order No. 2020-05, any businesses permitted to continue shall limit their activities to those deemed essential. Businesses that regularly conduct operations that are both essential and non-essential are instructed to limit their activities to only those that are essential as authorized in Executive Order 2020-05 and applicable guidance issued by the Department of Public Health and Social Services ("DPHSS"). Each and every sale of a non-essential item may be deemed a violation by the business and enforceable pursuant to Section 5 below.
5. **ENFORCEMENT.** Individuals and businesses who refuse to comply with this Order or any of the applicable provisions of Executive Order Nos. 2020-03, 2020-04, 2020-05 or 2020-06, shall be subject to fines and/or, in the case of businesses, the termination of business licenses. The DPHSS and the Department of Revenue and Taxation ("DRT") may issue guidance relative to this Order. DPHSS and DRT shall enforce this Order and, if necessary, may do so with the assistance of the Guam Police Department.
6. **SEVERABILITY.** If any provision of this Order or its application to any person or circumstance is held invalid, the invalidity shall not affect other provisions or applications of this order that can be given effect without the invalid provision or application, and to this end, the provisions of this order are severable.

SIGNED AND PROMULGATED at Hagåtña, Guam, this **5th** day of **April 2020**.



LOURDES A. LEON GUERRERO
Maga'hågan Guåhan
Governor of Guam

Attested by:

JOSHUA F. TENORIO
Sigundo Maga'låhen Guåhan
Lieutenant Governor of Guam